

EnEV 730.02
ErP 812/2013
ErP 814/2013
SIA 384/1

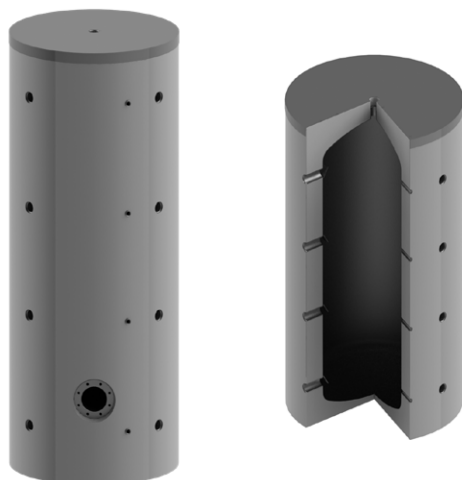

Bauart
Design | Structure | Struttura

Die Speicher werden aus hochwertigem Stahl nach EN 10025:2019 gefertigt.

EN The storage tanks are made from high quality steel in accordance with EN 10025:2019.

FR Les ballons sont fabriqués en acier de grande qualité, selon la norme EN 10025:2019.

IT Gli accumulatori sono realizzati in acciaio pregiato secondo la norma EN 10025:2019.

Betriebsdruck / Prüfdruck Operating pressure / test pressure Pression de service / Pression test Pressione d'esercizio / Pressione di collaudo	3 bar / 4.5 bar
Einsatzgebiet Application Application Applicazione	18°C – 95°C



Schutz vor Korrosion

Anti-corrosion protection | Protection contre la corrosion | Protezione anticorrosiva

Innen sind die Speicher unbehandelt. Aussen sind die Speicher mit PU-Schaum fix geschäumt.

EN The storage tanks are untreated on the interior. On the exterior the storage tanks are foamed with polyurethane foam.

FR À l'intérieur, les réservoirs ne sont pas traités. À l'extérieur, ils sont recouverts de mousse fixe.

IT L'interno degli accumulatori non è trattato. All'esterno gli accumulatori presentano una copertura di schiuma PU fissa.

Isolierung

Insulation | Isolation | Isolamento

PUR-Hartschaum

60 mm PUR-Hartschaum fix geschäumt. Skaimantel 5 mm mit Reissverschluss vormontiert, inklusive Rosetten und Abdeckhaube. Brandschutzklasse B2. Silber. Weitere Farben nach Absprache.

EN Rigid polyurethane foam (PUR) 60 mm rigid polyurethane foam. Skai jacket 5 mm with zip preassembled, including cover plates and hood. Fire-resistance rating B2. Silver. Other colours on request.

FR Mousse solidifiée PUR 60 mm de mousse dure PUR Enveloppe en skaï de 5 mm préinstallée avec fermeture à glissière, y compris rosettes et capot. Classe allemande de protection incendie B2. Argent. Autres couleurs après concertation.

IT Schiuma PUR rigida 60 mm di schiuma rigida di poliuretano fissa. Mantello in skaï da 5 mm pre-assemblato con cerniera, dotato di rosette e calotta di copertura. Classe di resistenza antincendio B2. Argento. Altri colori su richiesta.

≤ 600 L

PUR (Polyurethane)
B2; $\lambda = 0.026 \text{ W/(mK)}$

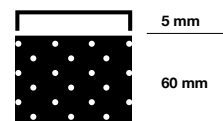

5 mm

60 mm

Pufferspeicher
Buffer storage tanks
Ballon tampon
Accumulatori tampone
PSF 200 – 600

200 – 600

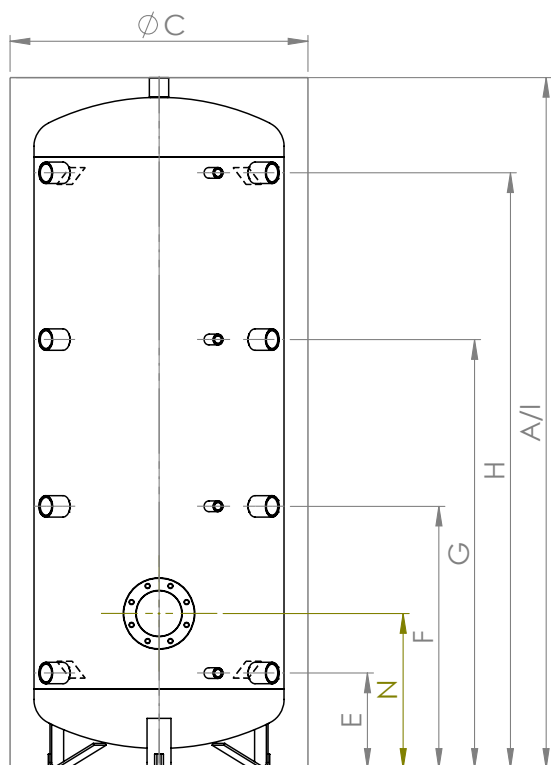

200 – 600

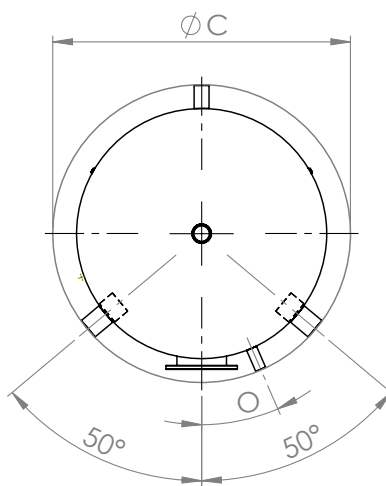

200 – 600

Isolierung Insulation Isolation Isolamento		60 mm fix eingeschäumt Fixed with foam Enrobage mousse fixe Schiuma rigida fissa				
Verwendung Usage Utilisation Uso	Dimension Dimension Dimension Dimensione	200	300	400	500	600
Wärmeverlust Heat losses Pertesthermiques Perdita di calore	kWh/24h	1.01	1.44	1.69	1.95	2.05
	W	43	60	71	82	86
ErP-Klasse ErP class Classe ErP Classe ErP		A	B	B	B	B
Gewicht Weight Poids Peso	kg	46	60	72	83	91
Art.Nr. Part no. Réf. Art.n.	200104...	0200	0300	0400	0500	0600
Elektroheizung zum Einschrauben* Screw-in Immersion heater* Résistances à visser* Resistenza elettrica da avvitare*	bis kW to à a	3.0	4.5	6.0	6.0	6.0



	Verwendung Usage Utilisation Uso	Dimension Dimension Dimension Dimensione	200	300	400	500	600
	Inhalt Capacity Contenance Contenuto	l	190	282	377	479	559
	Kippmass Tilted dimension Cote de basculement Altezza in raddrizzamento	mm	1360	1610	1590	1900	2140
A	Höhe mit Isolierung Height with insulation Hauteur avec isolation Altezza con isolamento	mm	1210	1470	1400	1740	2000
C	Ø mit Isolierung with insulation avec isolation con isolamento	mm	600	650	750	750	750
E*	Anschluss 1 Connection Raccord Collegamento	- mm	215	240	240	240	240
		G"	1 ½"	1 ½"	1 ½"	1 ½"	1 ½"
		- G"	½"	½"	½"	½"	½"
F*	Anschluss 2 Connection Raccord Collegamento	- mm	475	570	550	660	750
		G"	1 ½"	1 ½"	1 ½"	1 ½"	1 ½"
		- G"	½"	½"	½"	½"	½"
G*	Anschluss 3 Connection Raccord Collegamento	- mm	735	900	850	1080	1250
		G"	1 ½"	1 ½"	1 ½"	1 ½"	1 ½"
		- G"	½"	½"	½"	½"	½"
H*	Anschluss 4 Connection Raccord Collegamento	- mm	995	1230	1160	1500	1760
		G"	1 ½"	1 ½"	1 ½"	1 ½"	1 ½"
		- G"	½"	½"	½"	½"	½"
I	Anschluss oben Connection above Raccord du haut Collegamento superiore	- mm	1210	1470	1400	1740	2000
		G"	1 ¼"	1 ¼"	1 ¼"	1 ¼"	1 ¼"
N	Flansch Flange Bride Flangia	- mm	345	370	390	390	390
		Ø - mm	180/120	180/120	180/120	180/120	180/120
O	Anordnung Fühler Positioning sensor Disposition sonde Disposizione sensore	°	15.0	18.5	23.5	23.5	23.5

*Einbaumöglichkeit: 1 x Elektroheizung zum Einschrauben
Installation option: 1 x Screw-in Immersion heater | Option d'installation: 1 x Résistances à visser | Opzione di installazione: 1 x Resistenza elettrica da avvitare

EnEV 730.02
ErP 812/2013
ErP 814/2013
SIA 384/1



Bauart

Design | Structure | Struttura

Die Speicher werden aus hochwertigem Stahl nach EN 10025:2019 gefertigt.

EN The storage tanks are made from high quality steel in accordance with EN 10025:2019.

FR Les ballons sont fabriqués en acier de grande qualité, selon la norme EN 10025:2019.

IT Gli accumulatori sono realizzati in acciaio pregiato secondo la norma EN 10025:2019.

Betriebsdruck / Prüfdruck Operating pressure / test pressure Pression de service / Pression test Pressione d'esercizio / Pressione di collaudo	3 bar / 4.5 bar
Einsatzgebiet Application Application Applicazione	18°C – 95°C

Schutz vor Korrosion

Anti-corrosion protection | Protection contre la corrosion | Protezione anticorrosiva

Innen sind die Speicher unbehandelt. Aussen sind die Speicher grundiert.

EN The storage tanks are untreated on the interior. Tanks are primed on the outside.

FR À l'intérieur, les réservoirs ne sont pas traités. A l'extérieur, les réservoirs sont apprêtés.

IT L'interno degli accumulatori non è trattato. Gli accumulatori sono primerizzati all'esterno.



Isolierung

Insulation | Isolation | Isolamento

TopShell

Isolierung aus Hightech Faservlies. Skaimantel mit Reißverschluss, inklusive Rosetten und Abdeckhaube. Brandschutzklasse B2. Silber. Lose geliefert.

Variante

Isolierung aus Hightech Faservlies. PS-Mantel und Hakenleiste, inklusive Rosetten und Abdeckhaube. Brandschutzklasse B2. Farbe Silber.

EN TopShell

Insulation made of high-tech fibre fleece. Skai jacket with zip, including cover plates and hood. Fire-resistance rating B2. Silver. Supplied loose.

Alternative

Insulation made of high-tech fibre fleece. PS jacket and hook rack, including cover plates and hood. Fire-resistance rating B2. Silver.

FR TopShell

Isolation en tissu fibreux high-tech Enveloppe en skai avec fermeture à glissière, y compris rosettes et capot. Classe allemande de protection incendie B2. Argent. Livrée non montée.

Alternative

Isolation en tissu fibreux high-tech Enveloppe en PS équipée d'un support à crochets préinstallé, y compris rosettes et capot. Classe allemande de protection incendie B2. Couleur argent.

IT TopShell

Isolamento in tessuto non tessuto high-tech. Mantello in skai pre-assemblato con cerniera, dotato di rosette e calotta di copertura. Classe di resistenza antincendio B2. Argento. Consegna sfusa.

Alternativa

Isolamento in tessuto non tessuto high-tech. Mantello in PS e barra con ganci, rosette e calotta di copertura incluse. Classe di resistenza antincendio B2. Colore argento.

TopShell

B2; $\lambda = 0.038 \text{ W/(mK)}$

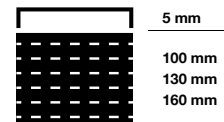

5 mm

100 mm

130 mm

160 mm

Pufferspeicher
Buffer storage tanks
Ballon tampon
Accumulatori tampone
PSF 300 – 5000

Verwendung Usage Utilisation Uso		300	500	600	800	900	1000	1050	1250	1500	1600	1800	1950	2000	2500	3000	4000	5000	
TopShell 100	Wärmeverlust Heat losses Pertesthermiques Perdita di calore	kWh/24h	2.06	2.61	2.89	3.12	3.38	3.38	3.49	3.82	-	-	-	-	-	-	-	-	-
		W	86	109	121	130	141	141	146	160	-	-	-	-	-	-	-	-	-
	ErP-Label ErP class Classe ErP Classe ErP	C	C	C	C	C	C	C	C	C	-	-	-	-	-	-	-	-	-
	CH SIA 384/1 Ta ≤ 90°C	X	X	•	•	•	•	•	•	•	X	X	X	X	X	X	X	X	X
	CH SIA 384/1 Ta ≤ 50°C	X	X	•	•	•	•	•	•	•	X	X	X	X	X	X	X	X	X
	EU Nr. 814/2013 (EU)	•	•	•	•	•	•	•	•	•	X	X	X	•	•	•	•	•	•
	A $\overline{\downarrow}$ [mm]	1400	1680	1700	1740	1820	2090	2050	2060	2200	1950	2205	2060	2420	2330	2770	2885	2920	
	C Ø [mm]	750	850	900	990	1050	990	1050	1150	1200	1300	1300	1450	1300	1450	1450	1600	1800	
	Art. Nr. 300107... Part no. Réf. Art.n.	0301	0501	0601	0801	0901	1001	1051	1251	1501*	1601*	1801	1951	2001	2501	3001	4001	5001	
	TopShell 130	Wärmeverlust Heat losses Pertesthermiques Perdita di calore	kWh/24h	-	-	-	-	-	-	-	4.00	4.08	4.35	-	-	-	-	-	-
		W	-	-	-	-	-	-	-	167	170	182	-	-	-	-	-	-	
ErP-Label ErP class Classe ErP Classe ErP		-	-	-	-	-	-	-	-	C	C	C	-	-	-	-	-	-	
CH SIA 384/1 Ta ≤ 90°C		X	X	•	•	•	•	•	•	•	•	•	X	X	X	X	X	X	
CH SIA 384/1 Ta ≤ 50°C		X	X	•	•	•	•	•	•	•	•	•	X	X	X	X	X	X	
EU Nr. 814/2013 (EU)		•	•	•	•	•	•	•	•	•	•	•	•	•	•	•	•	•	
A $\overline{\downarrow}$ [mm]		1430	1710	1730	1770	1850	2120	2080	2090	2230	1980	2235	2090	2450	2360	2800	2915	2950	
C Ø [mm]		810	910	960	1050	1110	1050	1110	1210	1260	1360	1360	1510	1360	1510	1510	1660	1860	
Art. Nr. 300107... Part no. Réf. Art.n.		0302*	0502*	0602*	0802*	0902*	1002*	1052*	1252*	1502	1602	1802*	1952*	2002*	2502*	3002*	4002*	5002*	
TopShell 160		Wärmeverlust Heat losses Pertesthermiques Perdita di calore	kWh/24h	-	-	-	-	-	-	-	-	-	-	-	-	-	-	-	-
		W	-	-	-	-	-	-	-	-	-	-	-	-	-	-	-	-	
	ErP-Label ErP class Classe ErP Classe ErP	-	-	-	-	-	-	-	-	-	-	-	-	-	-	-	-	-	
	CH SIA 384/1 Ta ≤ 90°C	X	X	•	•	•	•	•	•	•	•	•	X	X	X	X	X	X	
	CH SIA 384/1 Ta ≤ 50°C	X	X	•	•	•	•	•	•	•	•	•	•	•	•	•	•	•	
	EU Nr. 814/2013 (EU)	•	•	•	•	•	•	•	•	•	•	•	•	•	•	•	•	•	
	A $\overline{\downarrow}$ [mm]	1460	1740	1760	1800	1880	2150	2110	2120	2260	2010	2265	2120	2480	2390	2830	2945	2980	
	C Ø [mm]	870	970	1020	1110	1170	1110	1170	1270	1320	1420	1420	1570	1420	1570	1570	1720	1920	
	Art. Nr. 300107... Part no. Réf. Art.n.	0303*	0503*	0603*	0803*	0903*	1003*	1053*	1253*	1503*	1603*	1803*	1953	2003	2503	3003	4003	5003	

Ta = Auslegungstemperatur

Ta = dimensioning temperature | Ta = température de conception | Ta = temperatura di progetto

* Keine Lagerware.

Not in stock. | Marchandise non stockée. | Merce non a magazzino.

Nicht zugelassen | None approved | Non agréée | Non omologato

Zugelassen (Empfohlene Isolierung)
Approved (Recommended insulation) | Agréée (Isolation recommandée) | Omologato (Isolamento consigliato)

Zugelassen (oberhalb Mindestanforderung)
Approved (Exceeds minimum requirements) | Agréée (Supérieure aux exigences minimales requises) | Omologato (Requisito minimo superiore)

300 – 5000

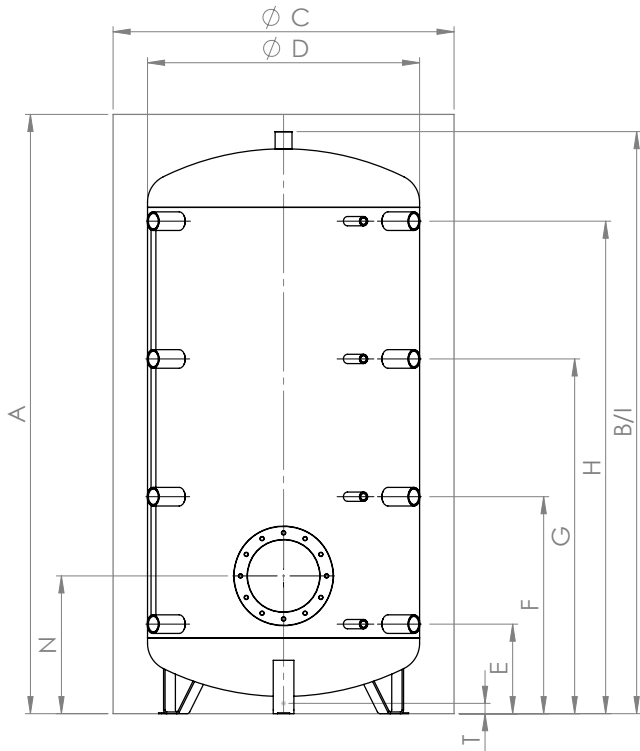

300 – 5000

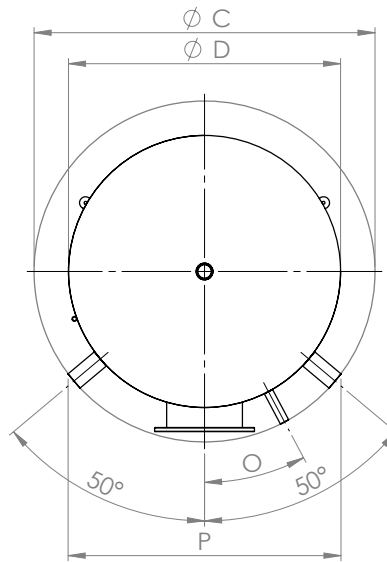

300 – 5000



Verwendung Usage Utilisation Uso	Dimension Dimension Dimensione	300	500	600	800	900	1000	1050	1250	1500	1600	1800	1950	2000	2500	3000	4000	5000
Inhalt Capacity Contenance Contenuto	l	279	480	560	718	870	887	996	1266	1500	1555	1830	2005	2021	2304	2852	3759	5003
Kippmass Tilted dimension Cote de basculement Altezza in raddrizzamento	mm	1380	1660	1680	1720	1800	2070	2020	2030	2180	1940	2190	2050	2390	2310	2740	2880	2920
P Einbringmass Delivery dimensions Cote de mise en place Ingombro	100 mm	610	690	730	800	840	800	840	950	1000	1100	1100	1250	1100	1250	1250	1400	1600
	130 mm	660	740	780	840	890	840	890	970	1010	1100	1100	1250	1100	1250	1250	1400	1600
	160 mm	710	780	820	890	940	890	940	1010	1060	1130	1130	1250	1130	1250	1250	1400	1600
B Höhe ohne Isolierung Height without insulation Hauteur sans isolation Altezza senza isolamento	mm	1350	1620	1650	1685	1770	2040	1990	1998	2148	1902	2152	2007	2352	2267	2704	2835	2870
D Ø ohne Isolierung without insulation sans isolation senza isolamento	mm	550	650	700	790	850	790	850	950	1000	1100	1100	1250	1100	1250	1250	1400	1600
E* Anschluss 1 Connection Raccord Collegamento	- mm	220	220	230	260	310	310	310	310	380	320	320	495	320	535	380	505	400
	G"	1 1/2"	1 1/2"	1 1/2"	1 1/2"	1 1/2"	1 1/2"	1 1/2"	1 1/2"	2"	2"	2"	2"	2"	2"	2"	2"	2"
	- G"	1/2"	1/2"	1/2"	1/2"	1/2"	1/2"	1/2"	1/2"	1/2"	1/2"	1/2"	1/2"	1/2"	1/2"	1/2"	1/2"	1/2"
F* Anschluss 2 Connection Raccord Collegamento	- mm	470	620	610	630	700	745	745	745	825	740	820	875	900	975	1020	1110	1100
	G"	1 1/2"	1 1/2"	1 1/2"	1 1/2"	1 1/2"	1 1/2"	1 1/2"	1 1/2"	2"	2"	2"	2"	2"	2"	2"	2"	2"
	- G"	1/2"	1/2"	1/2"	1/2"	1/2"	1/2"	1/2"	1/2"	1/2"	1/2"	1/2"	1/2"	1/2"	1/2"	1/2"	1/2"	1/2"
G* Anschluss 3 Connection Raccord Collegamento	- mm	800	1010	990	1030	1080	1250	1250	1250	1350	1150	1320	1255	1490	1415	1680	1860	1810
	G"	1 1/2"	1 1/2"	1 1/2"	1 1/2"	1 1/2"	1 1/2"	1 1/2"	1 1/2"	2"	2"	2"	2"	2"	2"	2"	2"	2"
	- G"	1/2"	1/2"	1/2"	1/2"	1/2"	1/2"	1/2"	1/2"	1/2"	1/2"	1/2"	1/2"	1/2"	1/2"	1/2"	1/2"	1/2"
H* Anschluss 4 Connection Raccord Collegamento	- mm	1120	1385	1380	1430	1470	1710	1710	1710	1760	1570	1820	1635	2020	1855	2330	2410	2520
	G"	1 1/2"	1 1/2"	1 1/2"	1 1/2"	1 1/2"	1 1/2"	1 1/2"	2"	2"	2"	2"	2"	2"	2"	2"	2"	2"
	- G"	1/2"	1/2"	1/2"	1/2"	1/2"	1/2"	1/2"	1/2"	1/2"	1/2"	1/2"	1/2"	1/2"	1/2"	1/2"	1/2"	1/2"
I Anschluss oben Connection above Raccord du haut Collegamento superiore	- mm	1350	1620	1650	1685	1770	2040	1990	1998	2148	1902	2152	2007	2352	2267	2704	2835	2870
	G"	1 1/4"	1 1/4"	1 1/4"	1 1/4"	3/4"	1 1/4"	1 1/4"	1 1/4"	1 1/4"	1 1/4"	3/4"	1 1/4"	1 1/4"	1 1/4"	1 1/4"	1 1/4"	1 1/4"
N Flansch Flange Bride Flangia	- mm	300	340	330	400	400	400	400	395	450	425	425	585	425	755	600	595	640
	Ø - mm	180/120										290/220						
T Bodenmuffe Ground fitting Manchon de fond Manicotto a pavimento	- mm	-	-	-	-	-	-	-	-	-	-	-	123	-	123	110	75	50
	G"	-	-	-	-	-	-	-	-	-	-	-	1 1/4"	-	1 1/4"	1 1/4"	1 1/4"	1 1/4"
O Anordnung Fühler Positioning sensor Disposition sonde Disposizione sensore	°	18.5	23.5	28.0	28.0	29.8	28.0	29.8	32.0	33.0	34.5	34.5	36.0	34.5	36.0	36.0	37.5	39.0
Gewicht Weight Poids Peso	kg	58	78	84	97	100	111	117	158	168	174	180	227	201	239	285	364	431
Art.Nr. 100 mm Part no. Réf. Art.n.	200104...	0301	0501	0601	0801	0901	1001	1051	1251	1501	1601	1801	1951	2001	2501	3001	4001	5001
Art.Nr. 130 mm Part no. Réf. Art.n.	200104...	0302	0502	0602	0802	0902	1002	1052	1252	1502	1602	1802	1952	2002	2502	3002	4002	5002
Art.Nr. 160 mm Part no. Réf. Art.n.	200104...	0303	0503	0603	0803	0903	1003	1053	1253	1503	1603	1803	1953	2003	2503	3003	4003	5003
Max. Einbaulänge von Elektroheizungen Max. installation length of electric heaters Longueur maximale d'installation des chauffages électriques Lunghezza massima di installazione dei riscaldatori elettrici	mm	550	650	700	790	850	790	850	950	1000	1100	1100	1250	1100	1250	1250	1400	1600

*Einbaumöglichkeit: 1 x Elektroheizung zum Einschrauben
Installation option: 1 x Screw-in Immersion heater | Option d'installation: 1 x Résistances à visser | Opzione di installazione: 1 x Resistenza elettrica da avvitare