

**DIN**

**EN 12897**

**EnEV 730.02**

**ErP 812/2013**

**ErP 814/2013**



0808-5401

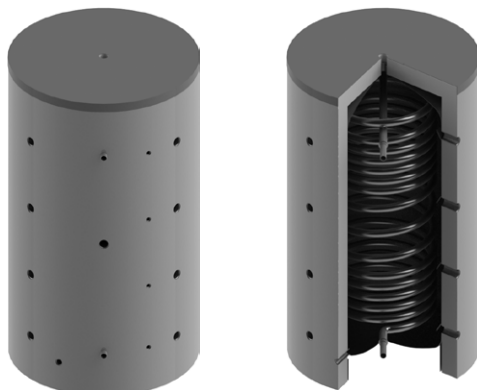

#### **Bauart**

**Design | Structure | Struttura**

Die Speicher werden aus hochwertigem Stahl nach EN 10025:2019 gefertigt.

Die Wärmetauscher bestehen aus Edelstahl V4A. Die Speicher sind innen unbehandelt.

**EN** The storage tanks are made from high quality steel in accordance with EN 10025:2019.

The heat exchanger is made from stainless steel (V4A).

The tanks are not treated on the inside.

**FR** Les ballons sont fabriqués en acier de grande qualité, selon la norme EN 10025:2019.

Les échangeurs de chaleur sont en acier inoxydable au molybdène.

L'intérieur des ballons n'est pas traité.

**IT** Gli accumulatori sono realizzati in acciaio pregiato secondo la norma EN 10025:2019.

Lo scambiatore di calore è realizzato in acciaio inossidabile V4A.

L'interno degli accumulatori non è trattato.

**Betriebsdruck / Prüfdruck**

Operating pressure / test pressure | Pression de service / Pression test | Pressione d'esercizio / Pressione di collaudo

3 bar / 4.5 bar

**Einsatzgebiet**

Application | Application | Applicazione

18°C – 95°C

**Schutz vor Korrosion**
**Anti-corrosion protection | Protection contre la corrosion | Protezione anticorrosiva**

Innen sind die Speicher unbehandelt. Aussen sind die Speicher grundiert.  
Der Wellrohrwärmetauscher ist aus hochwertigem Edelstahl V4A gefertigt.

**EN** The storage tanks are untreated on the interior. Tanks are primed on the outside. The corrugated pipe heat exchanger is made of high-quality stainless steel V4A.

**FR** À l'intérieur, les réservoirs ne sont pas traités. A l'extérieur, les réservoirs sont apprêtés. L'échangeur thermique est fabriqué en acier inoxydable V4A haut de gamme.

**IT** L'interno degli accumulatori non è trattato. Gli accumulatori sono primerizzati all'esterno. Lo scambiatore di calore a tubi corrugati è realizzato in pregiato acciaio inossidabile V4A.

**Wärmetauscher**
**Heat exchanger | Échangeur de chaleur | Scambiatore di calore**

**Brauchwasser:** Ein eingeschweisstes Wellrohr aus Edelstahl V4A

**EN Service water:** A welded corrugated tube from stainless steel V4A.

**FR Eau sanitaire:** Un tube ondulé soudé en Acier inoxydable V4A au molybdène.

**IT Acqua per uso domestico:** Un tubo ondulato saldato in acciaio inossidabile V4A.

<b>Betriebsdruck / Prüfdruck</b> Operating pressure / test pressure   Pression de service / Pression test   Pressione d'esercizio / Pressione di collaudo	6 bar / 12 bar
<b>Einsatzgebiet</b> Application   Application   Applicazione	max. 95°C Cl ≤ 70 mg/l ≤ 12°dH ≤ 21°fH

**Isolierung**
**Insulation | Isolation | Isolamento**
**TopShell**

Isolierung aus Hightech Faservlies. Skaimantel mit Reissverschluss, inklusive Rosetten und Abdeckhaube.  
Brandschutzklasse B2. Silber. Lose geliefert.

**Variante**

Isolierung aus Hightech Faservlies. PS-Mantel und Hakenleiste, inklusive Rosetten und Abdeckhaube.  
Brandschutzklasse B2. Farbe Silber.

**EN TopShell**

Insulation made of high-tech fibre fleece. Skai jacket with zip, including cover plates and hood. Fire-resistance rating B2. Silver. Supplied loose.

**FR TopShell**

Isolation en tissu fibreux high-tech Enveloppe en skai avec fermeture à glissière, y compris rosettes et capot. Classe allemande de protection incendie B2. Argent. Livrée non montée.

**IT TopShell**

Isolamento in tessuto non tessuto high-tech. Mantello in skai pre-assemblato con cerniera, dotato di rosette e calotta di copertura. Classe di resistenza antincendio B2. Argento. Consegna sfusa.

**Alternative**

Insulation made of high-tech fibre fleece. PS jacket and hook rack, including cover plates and hood. Fire-resistance rating B2. Silver.

**Alternative**

Isolation en tissu fibreux high-tech Enveloppe en PS équipée d'un support à crochets préinstallé, y compris rosettes et capot. Classe allemande de protection incendie B2. Couleur argent.



**Alternativa**

Isolamento in tessuto non tessuto high-tech. Mantello in PS e barra con ganci, rosette e calotta di copertura incluse. Classe di resistenza antincendio B2. Colore argento.

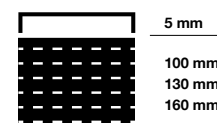
TopShell  
B2;  $\lambda = 0.038 \text{ W/(mK)}$



**Frischwasserspeicher**  
**Fresh water storage tank**  
**Ballon d'eau fraîche**  
**Accumulatori d'acqua dolce**  
**JH 600 – 2000**

Verwendung Usage   Utilisation   Uso		600	800	1000	1250	1500	2000	
TopShell 100	Wärmeverlust Heat losses Pertesthermiques Perdita di calore	kWh/24h	2.89	3.12	3.38	3.82	-	-
		W	121	130	141	160	-	-
	ErP-Label ErP class   Classe ErP   Classe ErP		C	C	C	C	-	-
	CH   SIA 384/1 Ta ≤ 90°C		•	•	•	•	X	X
	EU   Nr. 814/2013 (EU)		•	•	•	•	X	•
	A  [mm]		1700	1740	2090	2060	2200	2420
	C Ø [mm]		900	990	990	1150	1200	1300
	Art. Nr. 300113... Part no.   Réf.   Art.n.		0601	0801	1001	1251	1501*	2001
	Wärmeverlust Heat losses Pertesthermiques Perdita di calore	kWh/24h	-	-	-	-	4.00	-
		W					167	
ErP-Label ErP class   Classe ErP   Classe ErP		-	-	-	-	C	-	
CH   SIA 384/1 Ta ≤ 90°C		•	•	•	•	•	X	
EU   Nr. 814/2013 (EU)		•	•	•	•	•	•	
A  [mm]		1730	1770	2120	2090	2230	2450	
C Ø [mm]		960	1050	1050	1210	1260	1360	
Art. Nr. 300113... Part no.   Réf.   Art.n.		0602*	0802*	1002*	1252*	1502	2002*	
TopShell 160	Wärmeverlust Heat losses Pertesthermiques Perdita di calore	kWh/24h	-	-	-	-	-	-
		W	-	-	-	-	-	-
	ErP-Label ErP class   Classe ErP   Classe ErP		-	-	-	-	-	-
	CH   SIA 384/1 Ta ≤ 90°C		•	•	•	•	•	•
	EU   Nr. 814/2013 (EU)		•	•	•	•	•	•
	A  [mm]		1760	1800	2150	2120	2260	2480
	C Ø [mm]		1020	1110	1110	1270	1320	1420
	Art. Nr. 300113... Part no.   Réf.   Art.n.		0603*	0803*	1003*	1253*	1503*	2003

Ta = Auslegungstemperatur

Ta = dimensioning temperature | Ta = température de conception | Ta = temperatura di progetto

\* Keine Lagerware.

Not in stock. | Marchandise non stockée. | Merce non a magazzino.

Nicht zugelassen | None approved | Non agréée | Non omologato

Zugelassen (Empfohlene Isolierung)  
Approved (Recommended insulation) | Agréée (Isolation recommandée) | Omologato (Isolamento consigliato)

Zugelassen (oberhalb Mindestanforderung)  
Approved (Exceeds minimum requirements) | Agréée (Supérieure aux exigences minimales requises) | Omologato (Requisito minimo superiore)

**Frischwasserspeicher**  
**Fresh water storage tank**  
**Ballon d'eau fraiche**  
**Accumulatori d'acqua dolce**  
**JH 600 – 2000**

Typ JH		600	800	1000	1250	1500	2000
Bruttoinhalt Gross capacity   Contenance brute   Contenuto lordo	l	560	718	887	1266	1500	2015
Nettoinhalt Net capacity   Contenance nette   Contenuto netto	l	532	687	856	1215	1449	1964
Höhe ohne Isolierung Height without insulation   Hauteur sans isolation   Altezza senza isolamento	mm	1640	1710	2040	2010	2170	2370
Ø ohne Isolierung without insulation   sans isolation   senza isolamento	mm	700	790	790	950	1000	1100
Kippmass Tilted dimension   Cote de basculement   Altezza in raddrizzamento	mm	1690	1770	2100	2080	2250	2450
Einbringmass Delivery dimensions   Cote de mise en place   Ingombro	mm	730	800	800	950	1000	1100
Betriebsdruck Heizung Heater operating pressure   Pression de service du chauffage   Pressione d'esercizio riscaldamento	bar	3	3	3	3	3	3
Prüfdruck Heizung Heating test pressure   Pression test du chauffage   Pressione di collaudo riscaldamento	bar	4.5	4.5	4.5	4.5	4.5	4.5
Betriebsdruck Wasser Water operating pressure   Pression de service de l'eau   Pressione d'esercizio acqua	bar	6	6	6	6	6	6
Prüfdruck Wasser Water test pressure   Pression test de l'eau   Pressione di collaudo acqua	bar	12	12	12	12	12	12
max. Betriebstemperatur max. operating temperature   Temp. de service max.   Temperatura max. d'esercizio	°C	95	95	95	95	95	95
Gewicht Weight   Poids   Peso	kg	120	135	149	227	247	301
Art.Nr. 200205... Part no.   Réf.   Art.n.		0600	0800	1000	1250	1500	2000
<b>Isolierung</b> Insulation   Isolation   Isolamento	<b>EU</b>	<b>TopShell 100</b>				<b>TopShell 130</b>	<b>TopShell 100</b>
Wärmeverlust Heat losses   Pertesthermiques   Perdita di calore	kWh/24h	2.89	3.12	3.38	3.82	4.0	-
	W	121	130	141	160	167	-
ErP-Klasse ErP class   Classe ErP   Classe ErP		C	C	C	C	C	-
Gewicht Weight   Poids   Peso	kg	18	23	30	35	38	45
Art.Nr. 300113... Part no.   Réf.   Art.n.		0601	0801	1001	1251	1502	2001
<b>Isolierung</b> Insulation   Isolation   Isolamento	<b>CH</b>	<b>TopShell 100</b>				<b>TopShell 130</b>	<b>TopShell 160</b>
Art.Nr. 300113... Part no.   Réf.   Art.n.		0601	0801	1001	1251	1502	2003



Typ JH		600		800		1000		1250		1500		2000	
<b>Heizfläche Edelstahlwellrohr</b> Heating surface stainless steel corrugated pipe   Surface de chauffe du tube ondulé en acier inoxydable   Superficie riscaldante tubo ondulato	m <sup>2</sup>	5.5		6.0		6.0		9.8		9.8		9.8	
<b>Inhalt Edelstahlwellrohr</b> Stainless steel corrugated pipe capacity   Contenance du tube ondulé en acier inoxydable   Contenuto tubo ondulato	l	28.1		31.0		31.0		51.0		51.0		51.0	
<b>Puffertemperatur</b> Buffer tank temperature   Température du ballon   Temperatura tampone	°C	60	80	60	80	60	80	60	80	60	80	60	80
<b>Warmwasserdauerleistung</b> Hot water continuous output   Régime continu eau chaude   Potenza continua acqua calda 10°C / 45°C / 80°C	l / min	7.2	11.6	7.8	12.0	7.8	12.0	13.5	22.6	13.5	22.6	13.5	22.6
<b>max. Warmwasserdauerleistung</b> Max. hot water continuous output   Régime continu maxi eau chaude   Potenza continua acqua calda max.	kW	18	31	20	34	20	34	32	55	32	55	32	55

Frischwasserspeicher  
Fresh water storage tank  
Ballon d'eau fraiche  
Accumulatori d'acqua dolce  
JH 600 – 2000



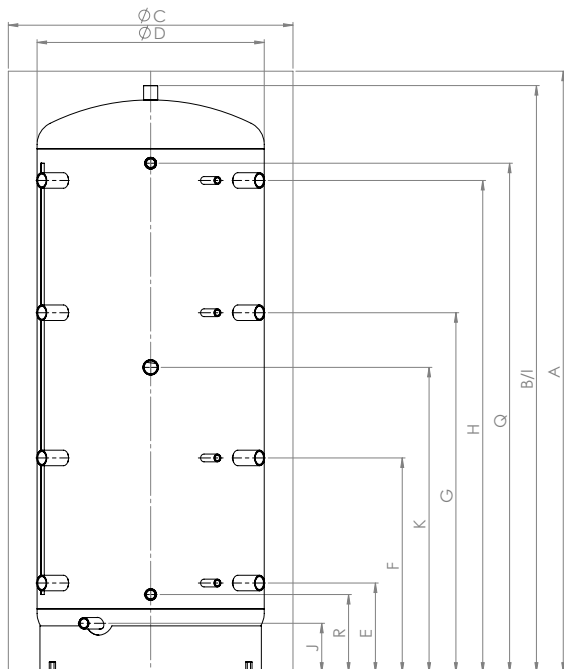



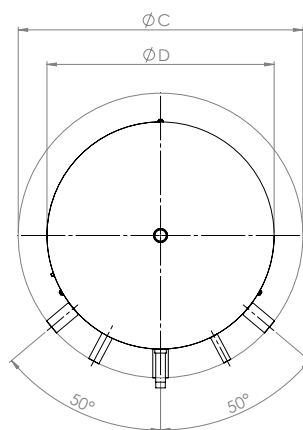





600 – 2000



600 – 2000



600 – 2000

	Verwendung Usage Utilisation Uso	Dimension Dimension Dimension Dimensione	600	800	1000	1250	1500	2000
B	Höhe ohne Isolierung Height without insulation   Hauteur sans isolation   Altezza senza isolaento	mm	1640	1710	2040	2010	2170	2370
D	Ø ohne Isolierung without insulation   sans isolation   senza isolaento	mm	700	790	790	950	1000	1100
E	Anschluss 1 Connection   Raccord   Collegamento	 – mm	230	260	310	310	380	320
		G"	1 ½"	1 ½"	1 ½"	1 ½"	1 ½"	1 ½"
		 – G"	½"	½"	½"	½"	½"	½"
F	Anschluss 2 Connection   Raccord   Collegamento	 – mm	610	630	745	745	825	900
		G"	1 ½"	1 ½"	1 ½"	1 ½"	1 ½"	1 ½"
		 – G"	½"	½"	½"	½"	½"	½"
G	Anschluss 3 Connection   Raccord   Collegamento	 – mm	990	1030	1250	1250	1350	1490
		G"	1 ½"	1 ½"	1 ½"	1 ½"	1 ½"	1 ½"
		 – G"	½"	½"	½"	½"	½"	½"
H	Anschluss 4 Connection   Raccord   Collegamento	 – mm	1380	1430	1710	1710	1760	2020
		G"	1 ½"	1 ½"	1 ½"	1 ½"	1 ½"	1 ½"
		 – G"	½"	½"	½"	½"	½"	½"
I	Anschluss oben Connection above   Raccord du haut   Collegamento superiore	 – mm	1640	1710	2040	2010	2170	2370
		G"	1 ¼"	1 ¼"	1 ¼"	1 ¼"	1 ¼"	1 ¼"
J	Anschluss unten Connection below   Raccord du bas   Collegamento inferiore	 – mm	145	170	170	190	235	220
		G"	1"	1"	1"	1"	1"	1"
K	Elektroheizung zum Einschrauben* Screw-in Immersion heater*   Résistances à visser*   Resistenza elettrica da avvitare*	 – mm	850	915	1060	1060	1350	1315
		G"	1 ½"	1 ½"	1 ½"	1 ½"	1 ½"	1 ½"
Q	Edelstahlwellrohr Warmwasser Hot water stainless steel corrugated pipe   Tube ondulé en acier inoxydable eau chaude   Scambiatore di calore con tubo ondulato in acciaio inossidabile	 – mm	1380	1450	1770	1680	1835	1805
		G" – Aussengewinde External thread Filet extérieur Filettatura esterna	1"	1"	1"	1"	1"	1"
R	Edelstahlwellrohr Kaltwasser Cold water stainless steel corrugated pipe   Tube ondulé en acier inoxydable eau froide   Tubo ondulato acqua fredda	 – mm	230	260	270	310	335	305
		G" – Aussengewinde External thread Filet extérieur Filettatura esterna	1"	1"	1"	1"	1"	1"

\*Einbaumöglichkeit: 1 x Elektroheizung zum Einschrauben  
Installation option: 1 x Screw-in Immersion heater | Option d'installation: 1 x Résistances à visser | Opzione di installazione: 1 x Resistenza elettrica da avvitare